

Preliminary study on phase-contrast digital tomosynthesis: development and evaluation of experimental system

Ai Ikeya¹⁾, Atsushi Teramoto¹⁾, Kenji Noguchi²⁾, Hiroshi Fujita³⁾

1) Faculty of Radiological Technology, Graduate School of Health Sciences, Fujita Health University, 1-98 Dengakugakubo, Kutsukake-cho, Toyoake-city, Aichi 470-1192, Japan;

2) Nagoya Electric Works Co., LTD, Mentoku 29-1, shinoda, Ama-city, Aichi 490-1294, Japan;

3) Department of Intelligent Image Information, Division of Regeneration and Advanced Medical Sciences, Graduate School of Medicine, Gifu University, 1-1 Yanagido, Gifu 501-1194, Japan;

ABSTRACT

The advantage of X-ray phase imaging is its ability to obtain information on soft tissues, which is difficult using conventional X-ray imaging. Moreover, a sharp X-ray image can be obtained from the edge effect resulting from phase contrast. Digital tomosynthesis is an imaging technique used to reconstruct multiple planes in a single scan. In this study, we developed an experimental system that combines the phase-contrast and digital tomosynthesis techniques. Our experimental system consists of a transmission-type micro-focus X-ray source (minimum focus size: 1 μm). We also introduced an indirect conversion-type flat panel detector (pixel pitch: 50 μm , matrix size: 2366 \times 2368) as an imaging device. The sample is placed on a computer-controlled rotation table, and projection images are captured from various angles. The images are then reconstructed using the filtered back projection method. In the experiments, a tomosynthesis image of an acrylic phantom was obtained at a tube voltage of 40 kV and at a maximum projection angle of $\pm 20^\circ$. To evaluate the edge enhancement effect by phase contrast, the resolution, degree of edge enhancement, and image contrast were measured using the acrylic phantom. A good edge enhancement effect was confirmed under the specified conditions. Furthermore, we compared to the shape between the projection image and the tomosynthesis image and found that the tomosynthesis image showed high shape reproducibility compared to the conventional projection image. These results indicate that phase-contrast digital tomosynthesis may be useful for the three-dimensional imaging of low-contrast material.

Key word: phase-contrast, tomosynthesis, transmission-type micro-focus X-ray source, conversion-type flat panel detector

1. INTRODUCTION

It has been reported that X-rays are refracted in the same manner as a light beam. The imaging based on this effect is called phase-contrast imaging; it has attracted attention from various fields[1]. The use of X-ray phase-contrast imaging has made it possible to obtain information on soft tissue, which was previously difficult by the conventional X-ray imaging. X-ray phase contrast imaging has been studied by many laboratories[2]-[4]. In fact, the effect has been applied to the clinical mammography. Since biological materials are three-dimensional, planar phase-contrast radiography often results in a complex and frequently confusing pattern of superimposed structures and boundaries. In order to overcome the effects of overlapping structures, tomosynthesis techniques have been developed to obtain a three-dimensional images, that have gained practical uses. Tomosynthesis is an imaging technique used to reconstruct multiple planes in a single scan. In this study, we developed an experimental system that combines the phase-contrast and digital tomosynthesis techniques as a basic study for achieving phase contrast tomosynthesis imaging, and reported on the performance evaluation results for this system.

2. METHODS AND MATERIALS

2.1 Experimental system

An experimental system was developed to evaluate the effect of phase-contrast tomosynthesis. In this chapter, we describe the experimental system and the imaging conditions.

2.1.1 Key parts of experimental system

We developed an experimental system using an X-ray tube and image receptor (Figs .1 and 2). We introduced a transmission-type microfocus X-ray tube (L11091, Hamamatsu Photonics) and an indirect conversion-type flat panel detector (C7942, Hamamatsu Photonics, pixel pitch = 50 μm , 2366 \times 2368 pixels) as the image receptor. Acrylic fiber (diameter = 5 mm and 2 mm) was used as a phantom (Fig.3). This phantom was used to evaluate the effect of phase contrast.

The phantom was placed on a computer-controlled rotation table and was rotated by $\pm 20^\circ$ about a central position with 1° increments. In our experimental setup, the phantom rotates around an axis while an X-ray source and a detector remain stationary. This setup is equivalent to an X-ray source and a detector revolving synchronously around a fixed object[5].

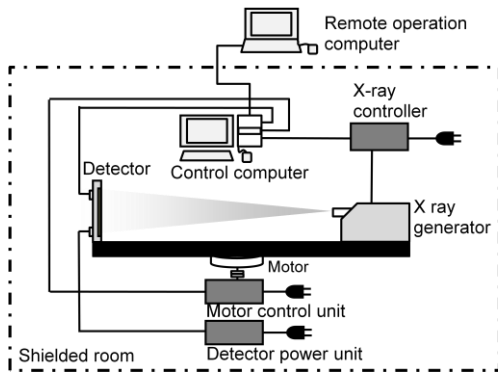

Fig.1 Schematic diagram of experimental system

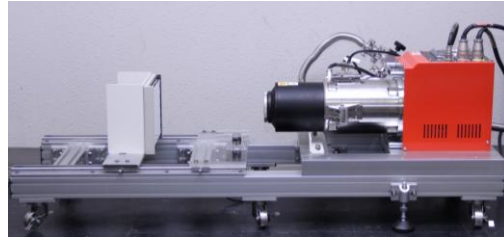

Fig. 2 Experimental system

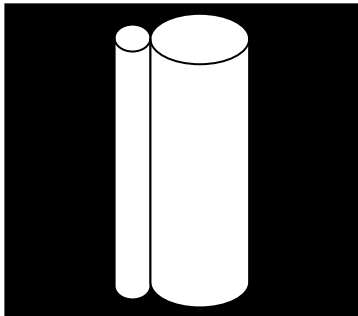

Fig.3. Schematic diagram of the phantom

2.1.2 Imaging conditions

We set the following geometric layout to express the phase-contrast effect in principle: source-to-object distance (SOD) of 4 cm and source-to-image-receptor distance (SID) of 36 cm. To verify the effectiveness of phase-contrast imaging, we also set the conventional imaging condition (geometric layout not to express the phase-contrast effect in principle): SOD of 2 cm and SID of 18 cm. The default imaging parameters were set to the following values: focus size, 1 μm ; tube voltage, 40 kV; and image-integration time, 120 s. These values were obtained by preliminary experiments we performed. Here, the tube current was adjusted in accordance with the SID - the tube current was set to 30 and 6 μA for SID of 40 and 20 cm. Dark correction was performed for projection images, and tomosynthesis images were reconstructed by filtered back projection algorithm. Image reconstruction was performed for an interval of 7 mm using a program that we developed.

2.2 Evaluation method

In order to evaluate the effect of edge enhancement on the phase contrast effect, the region of interest (ROI) was set to the projection images and tomosynthesis image of the cylinder phantom and profiled. Here ROI(1) and ROI(2) were used for projection and tomosynthesis images,

respectively (Fig.4). In addition, the pixel intensity profiles were obtained by integrating the pixel intensity along the vertical direction of each ROI.

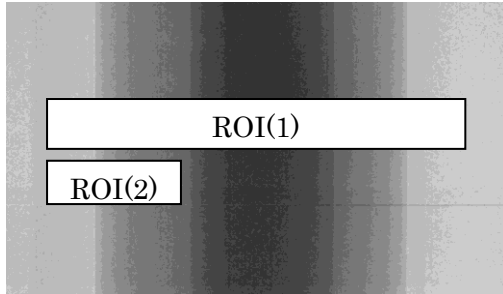

Fig.4 Evaluation regions

3. RESULTS

Figs 5 and 6 show the evaluation results for projection images and reconstruction images, respectively.

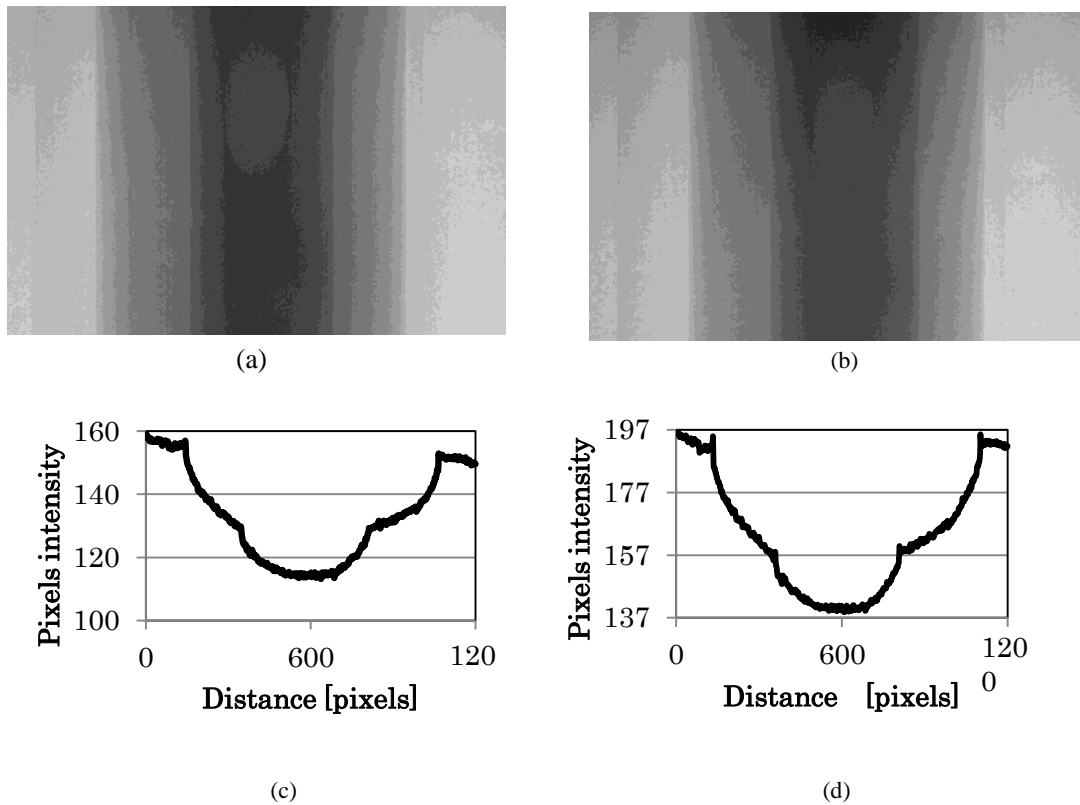
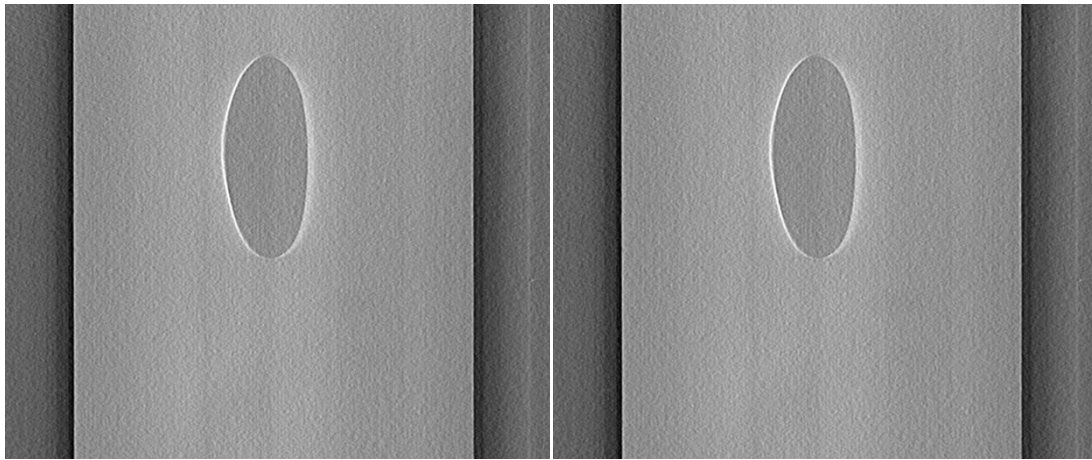

Fig.5 Evaluation results using projection images

- (a) : Phase-contrast projection image
- (b) : Conventional projection image
- (c) : Pixel intensity profile of (a)
- (d) : Pixel intensity profile of (b)



(a)

(b)

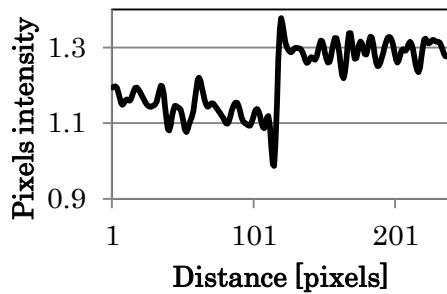

(c)

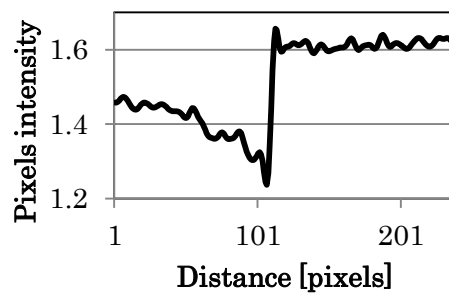

(d)

Fig.6 Evaluation results using tomosynthesis images

- (a) : Phase-contrast tomosynthesis image
- (b) : Conventional tomosynthesis image
- (c) : Pixel intensity profile of (a)
- (d) : Pixel intensity profile of (b)

4. DISCUSSION

Edge responses of phase-contrast projection and tomosynthesis images were better than those of conventional images. Regarding to tomosynthesis images, overlap of phantoms were resolved in the reconstructed image. Therefore, it is suggested that proposed method can improve both the separation of objects and the image sharpness.

5. CONCLUSION

We have developed an experimental system that combines the phase-contrast and digital tomosynthesis techniques. Experimental results indicate that phase-contrast digital tomosynthesis

may be useful for the three-dimensional imaging of low-contrast material.

REFERENCES

- [1] Somenkov V, Tkalich A, and Shkistein S : Refraction contrast in x-ray intoroscopy, Sov. Phys. Tech. Phys., 36(11), 1309-1311, 1991
- [2] Edwin FD, Ronald RP, David RP : Quantification of the effect of system and object parameters on edge enhancement in phase-contrast radiography. Med phys, 30(11), 2888-2896, 2003
- [3] Hiromu Ohara, Tomonori Gido, Akira Ishisaka et al : The Principle and Images of Phase-Contrast Mammography. Japanese journal of imaging and information sciences in medicine, 23(2), 27-33, 2006
- [4] Satoru Matsuo, Junji Morishita, Hiroshi Fujita et al : Evaluation of edge enhancement in a digital phase contrast. Japanese journal of imaging and information sciences in medicine, 23(4), 120-123, 2006
- [5] Z. Kolitsi, G. Panayiotakis, V. Anastassopoulus, A. Scodras, and N. Pallikarakis : A multiple projection method for didital tomosynthesis, Med. Phys. 19, 1045-1050, 1992
- [6] Ishisaka Akira, Ohara Hiromu, Honda Chika et al : Theoretical Analysis of Phase Contrast Imaging for Mammography. KONICA MINOLTA TECHNOLOGY REPORT, 2, 31-36, 2005